

- This document shows how to install your new Truck Guard onto your truck.
- Ensure that you have completely read and understand document **S017 - Safety** before beginning this installation procedure.
- You will require the following tools and supplies for installation:

Screwdrivers	Pliers	Socket Wrenches (various sizes)	Level
Wrenches (various sizes)	Sockets (various sizes)	Wire Ties	RTV Silicone (if truck equipped with parking sensors)



Figure 1a: Removing Black Panel Cover



Figure 1b: Removing Grill



Figure 1d: Top Bumper Valance Fastener Removal (Driver Side shown)

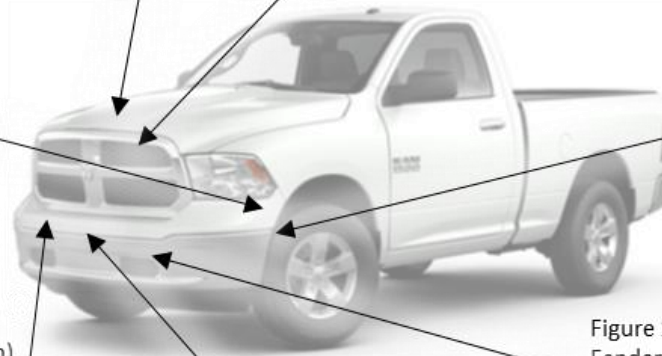

Figure 1c: Accessing the Headlight Tab & Fender fastener Removal (Driver Side shown)



Figure 1g: Side and Center Valance Support Removal (Passenger Side shown)



Figure 1f: Center Valance Support Clips



Figure 1e: Bumper Fastener Removal (Driver Side shown)

Figure 1: Removing the OEM front bumper (Your Truck may not be exactly as shown)

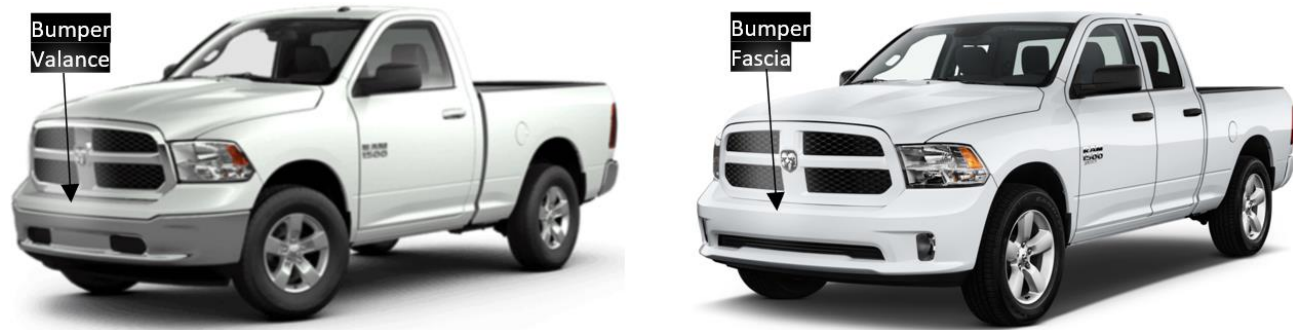

Figure 2: Bumper Valance vs Bumper Fascia

I. Removing the OEM front bumper

1. Open the hood and remove the black panel cover over the top of the grill by releasing the six push pins that hold it in place. See Figure 1a.
2. Remove the hood cable latch from the clip and set it to the side. Next remove the four bolts at the top of the grill using a 10mm socket. Remove the grill by gently pulling on it to release the tabs holding it in place. See figure 1b.
3. Open the access panel in the driver side wheel well by prying out the pin that secures it, as shown in Figure 1c. Next, reach in behind the headlight to push up on the tab behind it to release the headlight. This tab can be seen in Figure 1d. Repeat this Step for the passenger side headlight tab.
4. Remove the two bolts holding in the headlight with a 10mm socket. The first bolt is located above the headlight and the second is located near the bottom where the grill lower edge was resting. Lastly, remove the headlight, unplug the wiring harness, and set it aside. Repeat this step for both headlights.
5. Remove the bolt below the headlight enclosures on both sides that hold the top bumper valance in place (or bumper fascia depending on the truck). The threads of this fastener, shown in Figure 1d, are pointing towards the headlight so you will need to reach in with a 10mm socket to remove them.
6. Remove the bolts in the fender well, shown in Figure 1c, using an 8mm socket.
 - **For trucks with a top bumper valance**, shown in Figure 2, push down on the tabs along the top bumper valance to release them. Once the tabs released, carefully remove the top bumper valance from the truck. Next, unplug the parking sensor and fog light wiring harnesses from the bumper, if equipped.
 - **For trucks with a bumper fascia**, shown in Figure 2, remove the four lower fasteners from beneath the bumper fascia. Next, slowly pull the bumper fascia away from the truck while depressing the top tabs to release them. While pulling the bumper fascia away from the truck, make sure to unplug the parking sensor harness. Lastly, unplug the fog light wiring harness, if equipped.
7. Remove the three nuts, seen in Figure 1e, on the frame horn that secure the bumper in place using an 18mm socket. Repeat this on the opposite side frame horn for a total of six nuts. Next, carefully remove the bumper from the truck.
8. Remove the side valance support, shown in figure 1g, by removing the three bolts holding it in place with a 10mm socket.

9. Remove the center valance support by removing the four clips underneath it, seen in Figure 1f, and the two bolts on each side, seen in Figure 1g.
10. Reinstall the headlights by reversing Step 4 making sure to pull down on the white tab behind the headlights from the wheel well to lock the lights in place.
11. Reinstall the front grill by reversing Step 2.
12. Reinstall the black panel cover.



Figure 3c: Submount installation
(Your truck may not be exactly as shown)

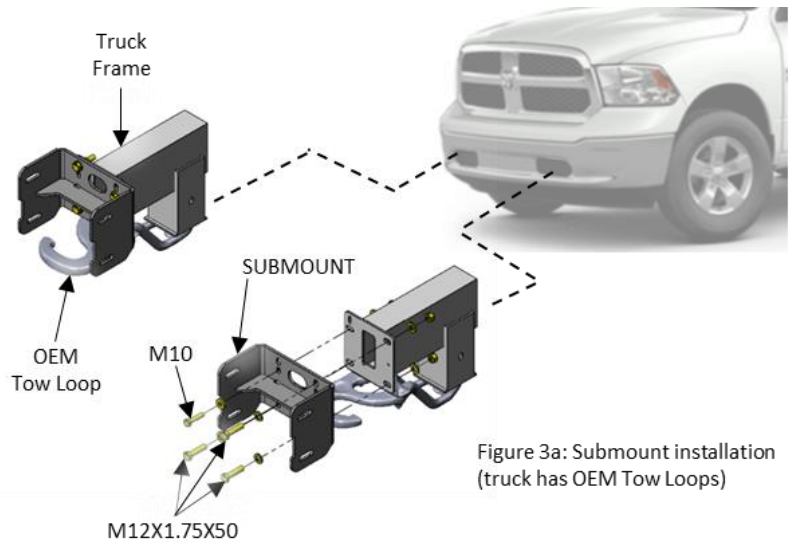

Figure 3a: Submount installation
(truck has OEM Tow Loops)

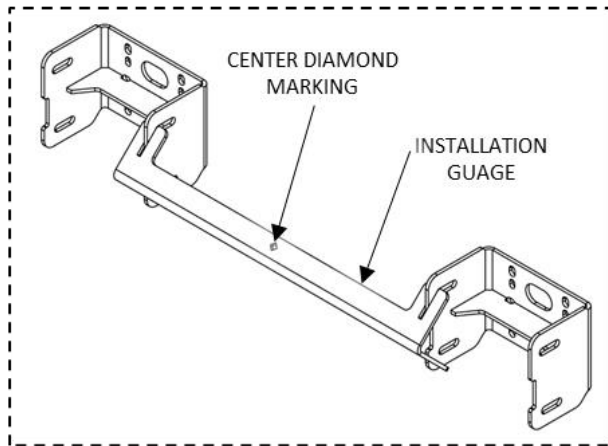

Figure 3d: Using the Installation Gauge

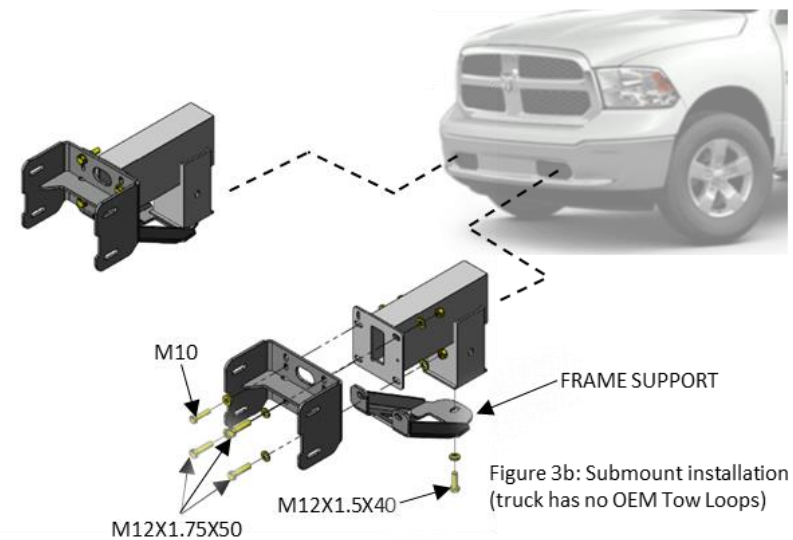

Figure 3b: Submount installation
(truck has no OEM Tow Loops)

Figure 3: Installing the Submounts

II. Installing the Submounts and Corner Covers

- Depending on your truck:
 - **For trucks with OEM Tow Loops:** Leave the tow loops installed in their existing positions and proceed to Step 2.
 - **For trucks without OEM Tow Loops:** Loosely install the Frame Support to the bottom of the truck frame using the provided M12 (fine thread) fastener. Make sure not to overtighten the fastener at this stage to allow for adjustment of the frame support. Ensure that the face of the frame support that features 2 slots, rests behind the truck frame horn, then proceed to Step 2.
- Install the Submounts to the truck frame by using the provided hardware, as shown in Figure 3c. Figures 3a and 3b illustrate the Submount installation for tow loop and non tow loop trucks respectively. Make sure to loosely install the fasteners such that the Submounts can be adjusted. Ensure that washers are used on the tow hook or frame support slots.
- Use the Installation Gauge to position the Submounts; the center diamond marking should line up with the center of the truck, see Figure 3d.
- With the Installation Gauge still in position, tighten all mounting fasteners. **Torque the M12 fasteners to 86 lb-ft and the M10 fasteners to 49 lb-ft.**
- Remove the Installation Gauge.
- Install the driver side Corner Cover, shown in Figure 4, using 1/4" hardware. Repeat this Step for the passenger side. The Corner Cover location can be adjusted by adding washers between the fender and the cover.

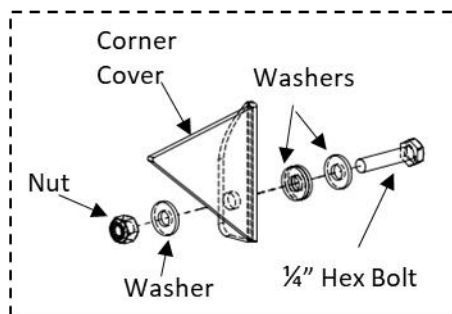

Figure 4: Corner Cover Installation
(Driver side shown)



Figure 5a: OEM fog light installation

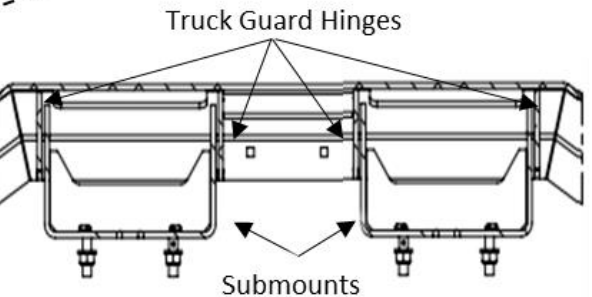
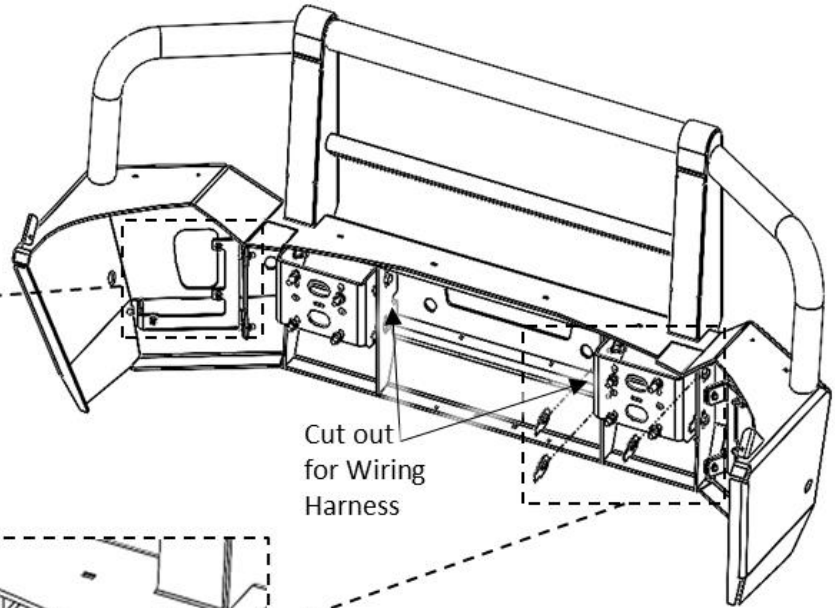

Figure 5b: Submount Position (Cut-away view from above)

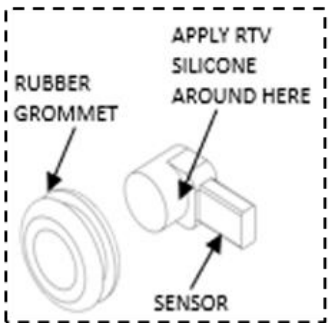

Figure 5d: Parking Sensor Installation

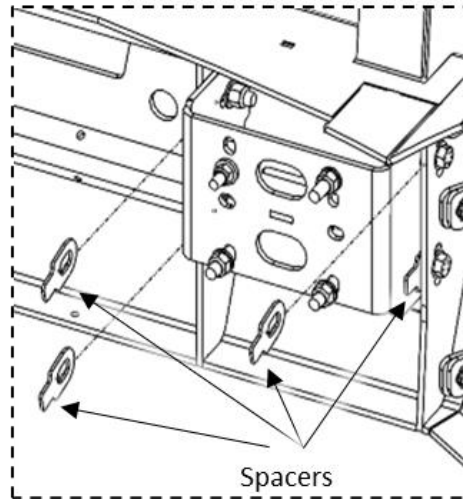

Figure 5c: Truck Guard Installation

Figure 5: Installing the Truck Guard (view from behind)

III. Installing the HERD Truck Guard

1. Remove the OEM fog lights from the OEM front bumper (if applicable).
2. Install the OEM fog lights with the provided Brackets to the HERD Truck Guard, as shown in Figure 5a.
3. Install the HERD Truck Guard to the Submounts; **follow the positioning shown in Figure 5b and Figure 5c**. Adjust the HERD Truck Guard and use the provided Spacers (1/16" and/or 1/8") as necessary. Tighten all mounting hardware after adjustment, and **torque 1/2" bolts to 96 lb-ft**.
4. If the truck has parking sensors, remove them from the OEM front bumper (sensor's bezel is not required) together with main wiring harness. Take note of the location of each sensor and harness. Apply RTV silicone all around the cylindrical section of the sensors, then insert the sensors through the rubber grommets on the HERD Truck Guard, see Figure 5d. Ensure locations of the sensors match where they were located on the OEM front bumper.
5. Let the adhesive cure at room temperature. Plug the main harness into each sensor and OEM fog light (if applicable). Connect the main harness to the truck's harness. Ensure that each sensor and OEM light functions normally. Secure loose wiring (main harness and block heater cord) with zip ties.

Important: Check mounting points' hardware after the first 5000 km and every 3-6 months. Re-torque as necessary.