

- This document shows how to install your new Truck Guard onto your truck.
- Ensure that you have completely read and understand document **S017 - Safety** before beginning this installation procedure.



Figure 1d: Remove OEM tow loops and lower frame extensions



Figure 1b: Remove back fasteners (Driver Side Shown)



Figure 1a: Remove front bumper clips (view from under)



Figure 1c: Remove front fasteners

Figure 1: Removing the OEM front bumper (Your Truck may not exactly as shown)

I. Removing the OEM front bumper

1. Remove the plastic clips on the rubber air dam and wiring harness from the bottom of the bumper as shown in Figure 1a.
2. Remove the 4 back fasteners (2 per side); these can be accessed either from under the truck or in front of the wheels, see Figure 1b.
3. Remove the 4 front fasteners (2 per side) as shown in Figure 1c. Next, remove the OEM bumper.
4. Remove OEM tow loops and lower frame extensions, see Figure 1d.

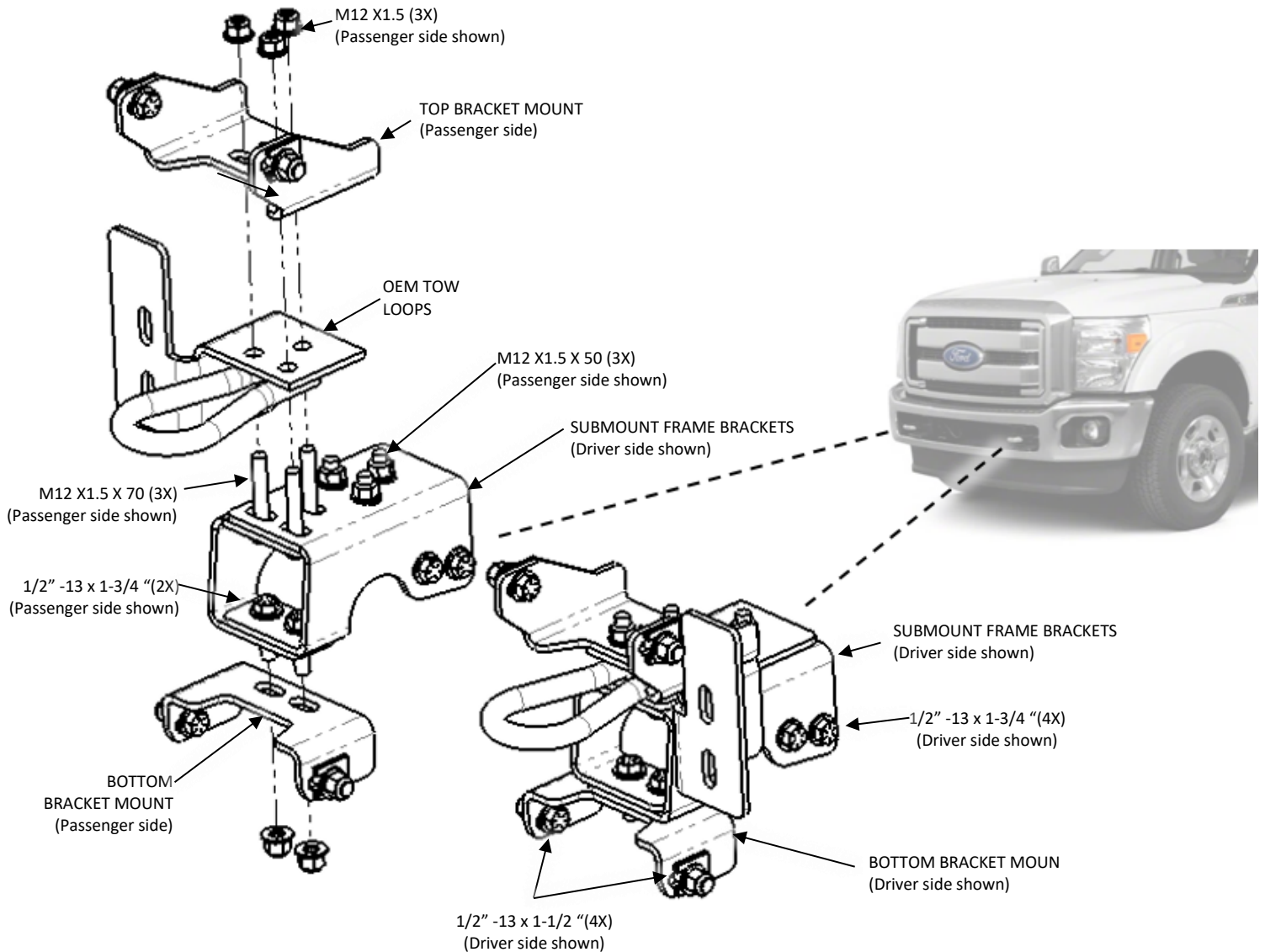

Figure 2: Installing the submounts

II. Installing the Submounts

1. Install the Submount Frame Brackets to the truck. Use the provided fasteners 1/2" and M12 (bolt and nuts), fasten loosely.
2. Install the OEM tow loops to the Submount Frame Bracket. Use the provided M12 fasteners (bolt), fasten loosely.
3. Tighten these fasteners, and torque to **84 lb-ft (M12)**.
4. Install the Top and Bottom Bracket Mounts as shown in Figure 2 above, Use the provided 1/2" fasteners (bolt and nuts) for the Bottom Bracket Mount and M12 fasteners (nuts) for the Top Bracket Mounts, fasten loosely.
5. Temporarily mount the Herd Truck Guard to the Submounts to check fitment. Once confirmed, unmount the Herd Truck Guard from the Submounts to tighten the Submount fasteners, and torque to **96 lb-ft (1/2")** and **84 lb-ft (M12)** accordingly.

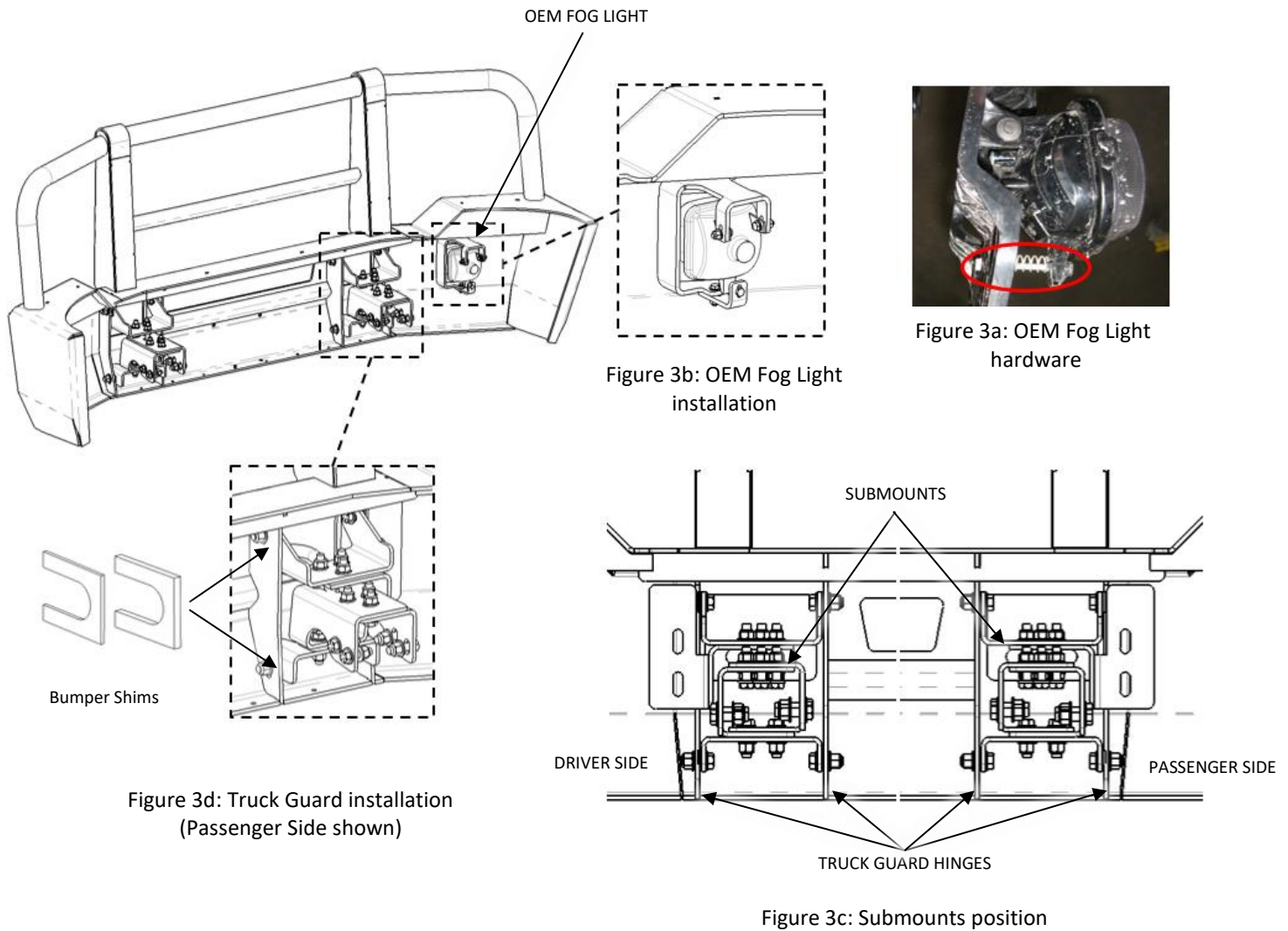

Figure 3: Installing the Truck Guard (view from behind)

III. Installing the HERD Truck Guard

1. Remove the OEM fog lights from the OEM front bumper (if applicable), keep the OEM adjusting screws and springs as shown in Figure 3a.
2. Install the OEM fog lights to the HERD Truck Guard as shown in Figure 3b. Fasten using the provided 1/4" fasteners (bolts and nuts); re-use the OEM adjusting screws and springs as shown in Figure 3b.
3. Install the HERD Truck Guard to the Submounts, **follow the position shown in Figure 3c**. Adjust the HERD Truck Guard and add Bumper Shims if necessary, see Figure 3d. Tighten all mounting fasteners after adjustment, and **torque to 96 lb-ft (1/2")**.
4. Plug the OEM harness into the OEM fog lights. Clean up loose wiring (harness and block heater cord) with zip ties.

Important: Check mounting point's hardware after the first 5000 km and every 3-6 months. Re-torque if necessary.