

- This document shows how to install your new Truck Guard onto your truck.
- Ensure that you have completely read and understand document **S017 - Safety** before beginning this installation procedure.

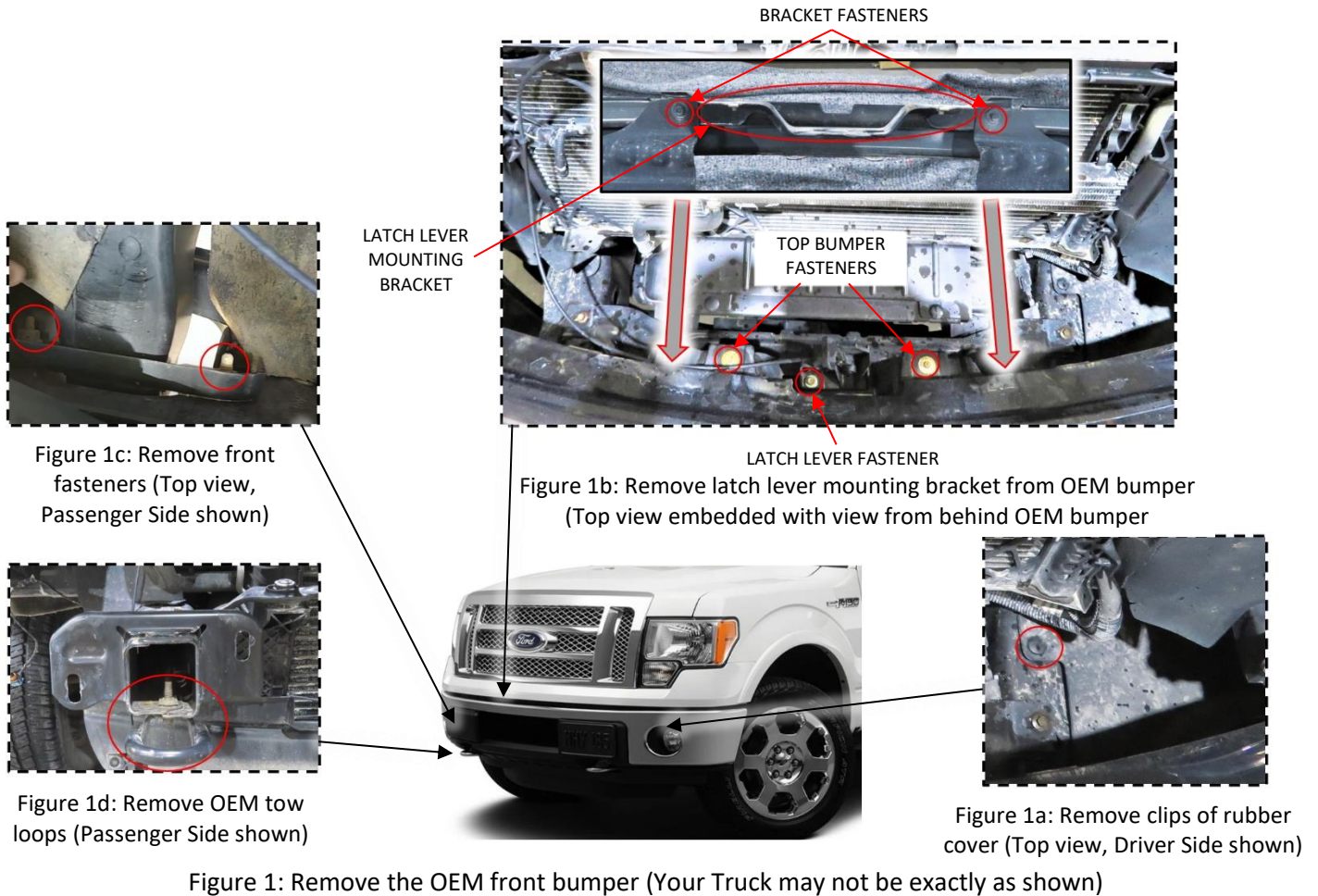

I. Removing the OEM front bumper

1. Unplug the wiring harness and detach the block heater cord (if applicable) from the OEM front bumper before removing it.
2. Open the hood and remove the plastic clips that connect the OEM bumper to the truck frame, see Figure 1a. Remove the 2 top bumper fasteners and 1 latch lever fastener as shown in Figure 1b. Save the fasteners for later use.
3. Remove the 4 front fasteners (2 per side). The fasteners' locations are shown in Figure 1c. Next, remove the OEM front bumper.
4. Remove the 2 bracket fasteners and latch lever mounting bracket from the OEM bumper, see Figure 1b. Reattach the latch lever mounting bracket and latch lever to the truck with OEM fasteners as shown in Figure 1b.
5. If the truck is equipped with OEM tow loops, remove the tow loops together with OEM fasteners for later usage, see Figure 1d.

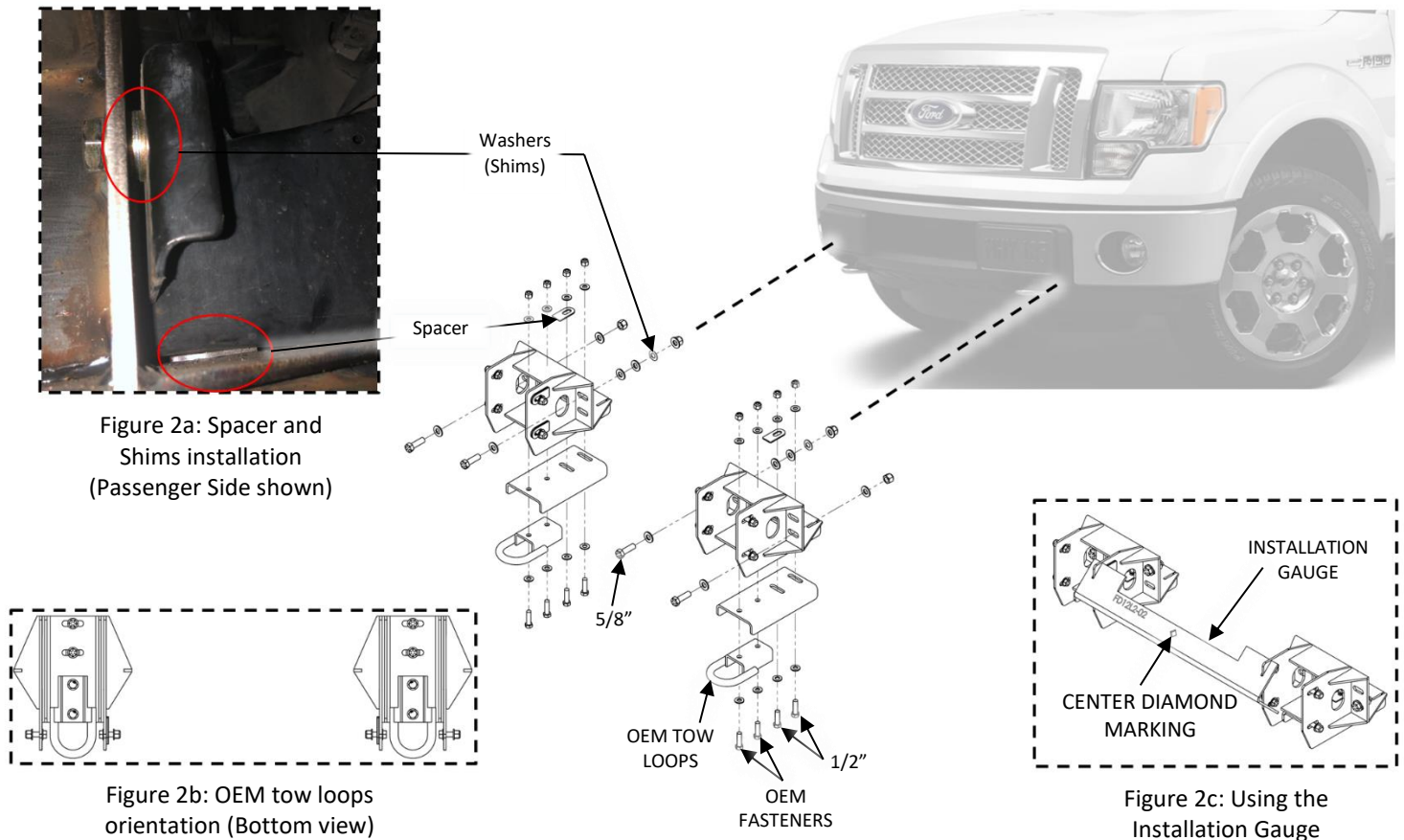

Figure 2: Installing the Submounts

II. Installing the Submounts

1. Install the Submounts. The Spacer should be placed between the Submounts and the bottom of truck frame, and Washers (Shims) should be placed between the Submounts and the front of truck frame, see Figure 2a.
Herd has found the best arrangement to be placing one 1/8" Spacer on the bottom of truck frame, two 1/8" Washers and one 3/64" Washer on the front of truck frame. You may need to find the best combination of Shims for your truck.
2. Install the OEM tow loops (if applicable) to the bottom of the Submounts with OEM fasteners as shown in Figure 2b. Fasten all fasteners loosely.
3. Use the Installation Gauge to position the Submounts, the center diamond marking should line up with the center of the truck, see Figure 2c.
4. With the Installation Gauge still in position, tighten all mounting fasteners (the bottom fasteners should be tightened first), and torque to **96 lb-ft (for 1/2")**, **191 lb-ft (for 5/8")**.
5. Remove the Installation Gauge.

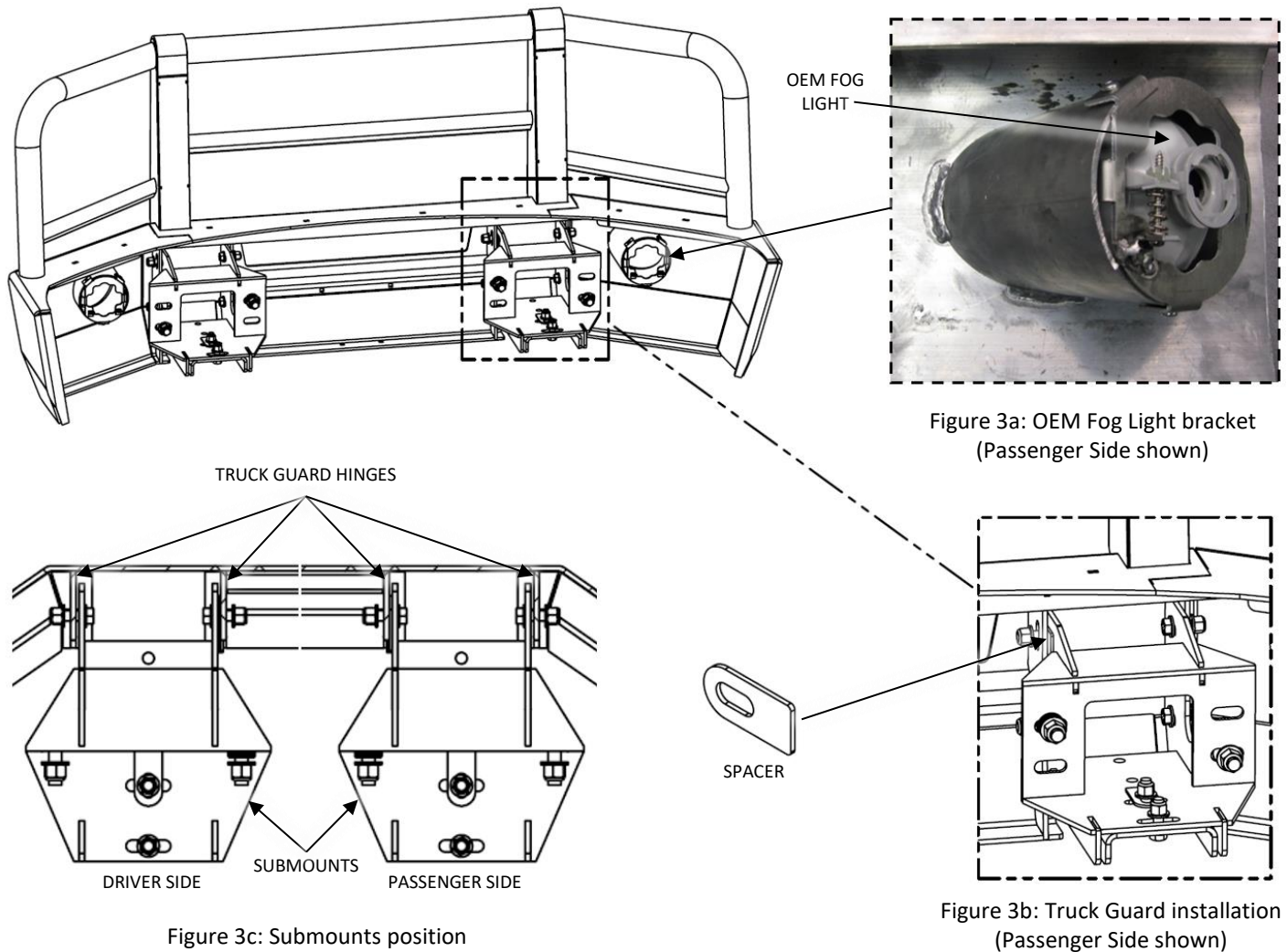

Figure 3: Installing the Truck Guard (view from behind)

III. Installing the HERD Truck Guard

1. Remove the OEM fog lights from the OEM front bumper (if applicable).
2. Install the OEM fog lights with the provided brackets on the HERD Truck Guard as shown in Figure 3a.
3. Attach the HERD Truck Guard to the Submounts. Use the provided fasteners (1/2") and spacers if necessary.
Follow the orientation shown in Figure 3b and Figure 3c. Adjust the HERD Truck Guard if necessary. Tighten all mounting fasteners after adjustment, and **torque to 96 lb-ft.**
4. Plug the clips and the wiring harness into the truck's wiring harness. Clean up loose wiring (harness and block heater cord if applicable) with zip ties.

Important: Check mounting point's hardware after the first 5000 km and every 3-6 months. Re-torque if necessary.