

- This document shows how to install your new Truck Guard onto your truck.
- Ensure that you have completely read and understand document **S017 - Safety** before beginning this installation procedure.

## I. Removing the OEM front bumper



Figure 1a: Remove rear fasteners (Driver Side shown)



Figure 1b: Remove CAS Radar (if applicable)

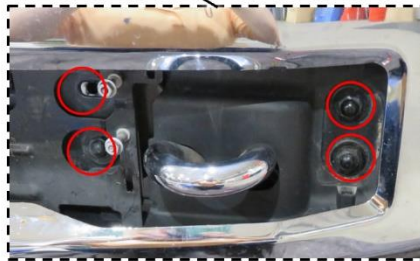

Figure 1c: Remove front fasteners

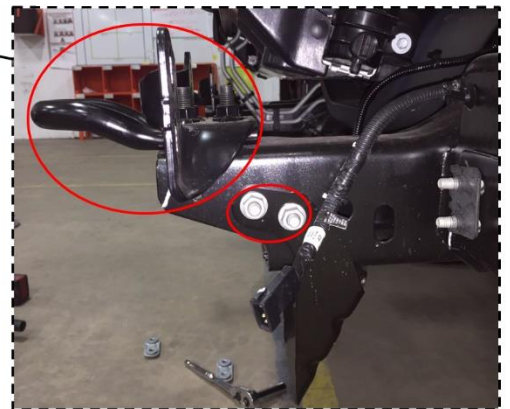

Figure 1d: Remove OEM tow loop and lower frame extension

Figure 1: Remove the OEM front bumper (Your Truck may not be exactly as shown)

1. Unplug the wiring harness and detach the block heater cord (if applicable) from the OEM front bumper before removing it.
2. Remove the 4 rear fasteners (2 per side); they can be accessed either from under the truck or from in front of the wheels as shown in Figure 1a.
3. Unplug and remove the CAS Radar (if applicable); see Figure 1b.
4. Remove the 8 front fasteners (4 per side), as shown in Figure 1c. Next, remove the OEM front bumper.
5. Remove the OEM tow loops and the lower frame extension; see Figure 1d. Keep the OEM tow loops, and their fasteners to be reused with HERD Truck Guard.

## II. Installing the Submounts



Figure 2a: Spacer orientation



Figure 2c: Using the Installation Gauge

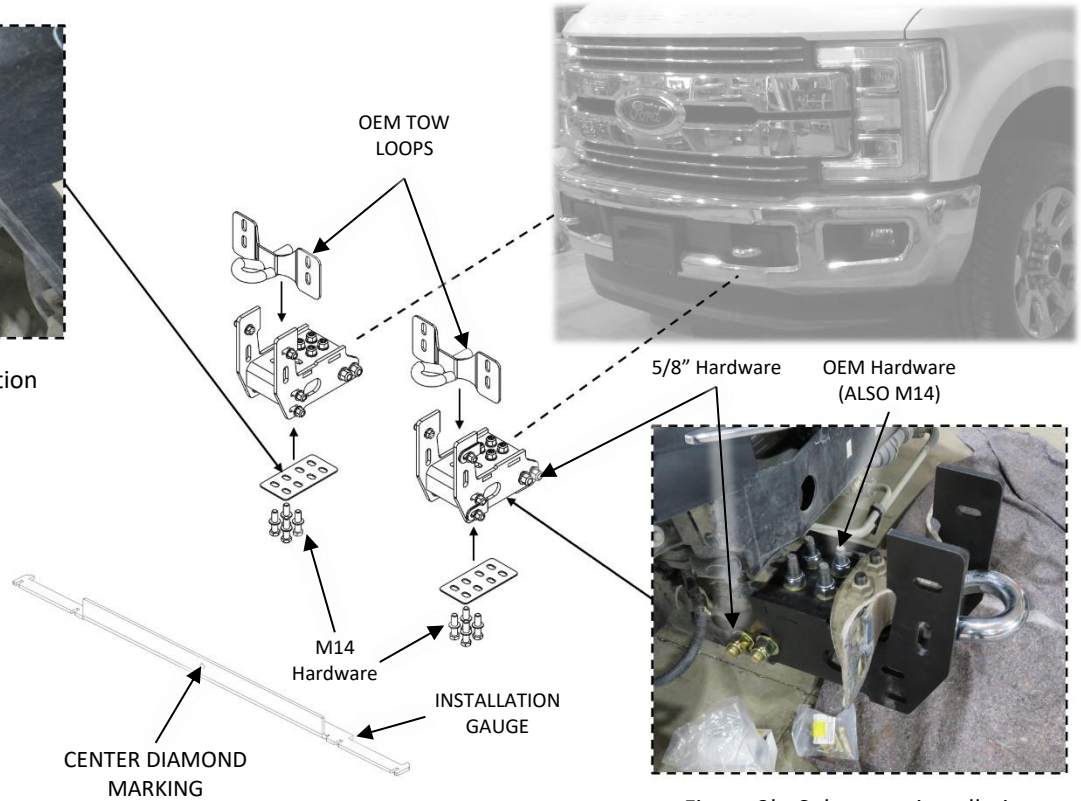

Figure 2b: Submount installation

Figure 2: Installing the Submounts

1. Place Spacers on top of the driver and passenger side frame as shown in Figure 2a.
2. Install the OEM tow loops and the Submounts as shown in Figure 2b. Use OEM tow loops' hardware together with the provided hardware (M14 and 5/8"), fasten loosely.
3. Use the Installation Gauge to position the Submounts; the center diamond marking should line up with the center of the truck, see Figure 2c.
4. With the installation gauge still in position, tighten all mounting hardware. Torque **the 5/8" to 191 lb-ft**; torque **the M14 to 133 lb-ft**.
5. Remove the Installation Gauge.

**III. Installing the HERD Truck Guard**

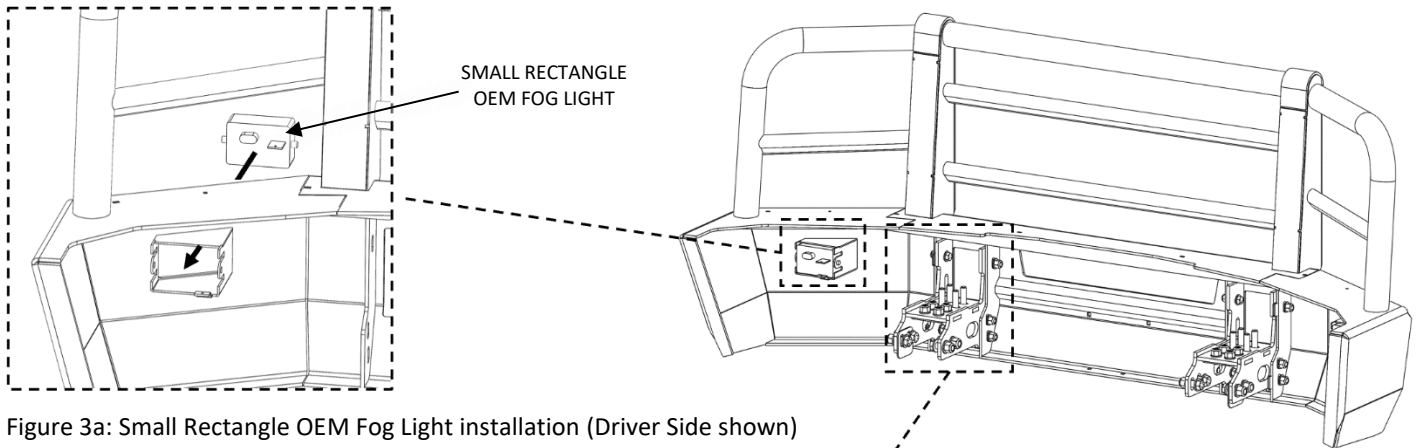

Figure 3a: Small Rectangle OEM Fog Light installation (Driver Side shown)

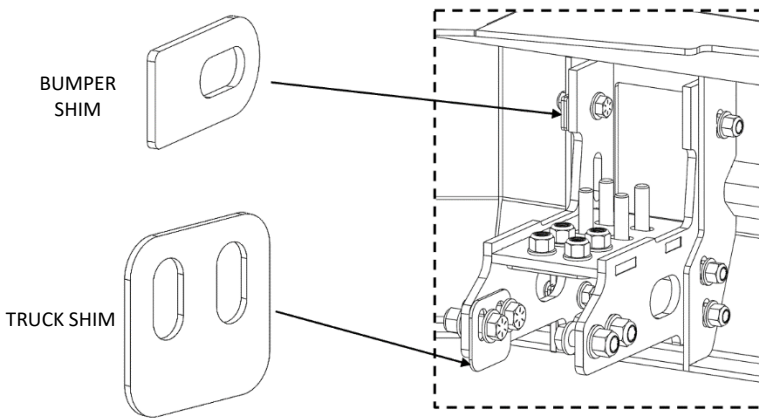

Figure 3b: Truck Guard installation (Driver Side shown)

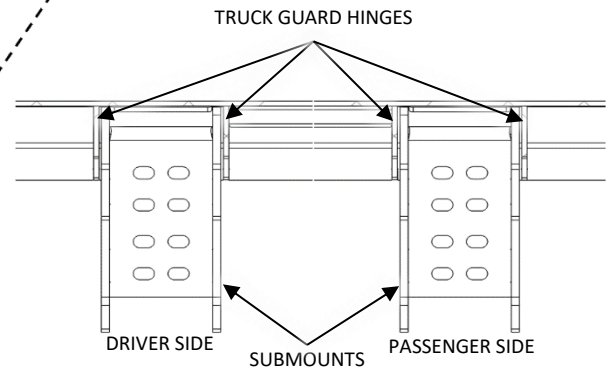

Figure 3c: Submounts position

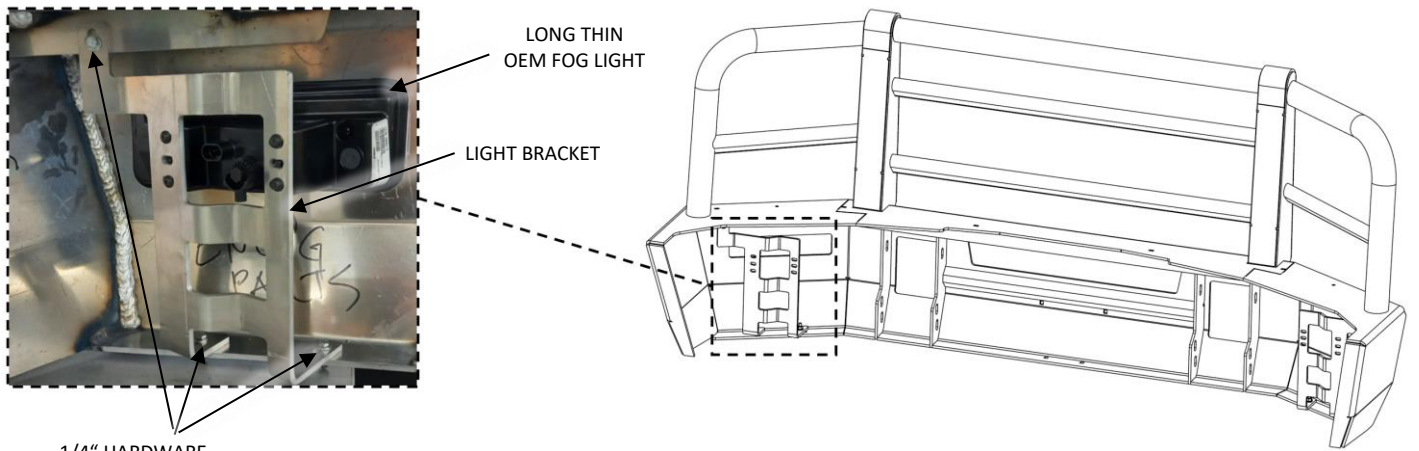

Figure 3d: Long Thin OEM Fog Light installation (Driver Side shown)

Figure 3: Installing the Truck Guard (view from behind)

1. Remove the OEM fog lights from the OEM front bumper (if applicable).
2. Install the OEM fog lights to HERD Truck Guard (if applicable); select the option that matches your truck:
  - a. For truck with **Small Rectangle** OEM fog lights, install the OEM fog light on the HERD Truck Guard (from the front of the Truck Guard) as shown in Figure 3a. Repeat this step on the other side of truck.
  - b. For truck with **Long Thin** OEM fog lights, install the OEM fog light on the Light Bracket, then install Light Bracket and OEM fog light assembly to the HERD Truck Guard using provided 1/4" Hardware as shown in Figure 3d. Repeat this step on the other side of truck.
3. Attach the HERD Truck Guard to the submounts. Use the provided hardware (1/2") and, if necessary, Bumper Shim and Truck Shim. **Follow the orientation shown in Figure 3b and Figure 3c.** Adjust the HERD Truck Guard if necessary. Tighten all mounting hardware after adjustment. **Torque the 1/2" Hardware to 96 lb-ft.**
4. Plug the wiring harness into each fog light and the truck's wiring harness.

**Important: Check mounting point's hardware after the first 5000 km and every 3-6 months. Re-torque if necessary.**