

- This document shows how to install your new Truck Guard onto your truck.
- Ensure that you have completely read and understand document **S017 - Safety** before beginning this installation procedure.

I. Removing the OEM Front Bumper

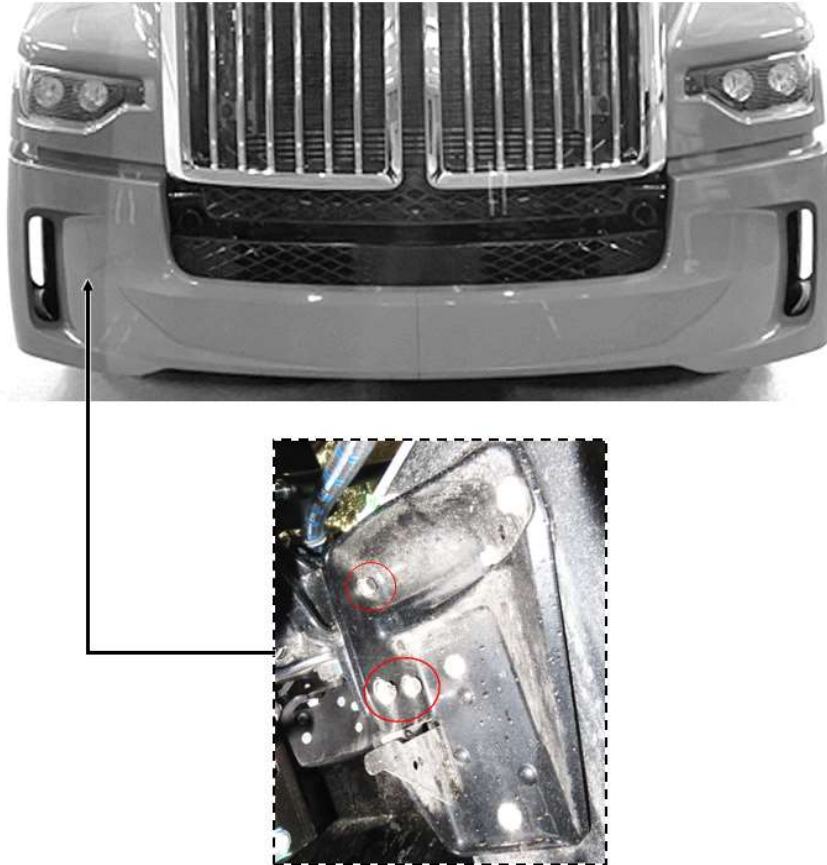

Figure 1a: OEM Front Bumper Fasteners
(PS Shown)

Figure 1: Removing the OEM Front Bumper (Your Truck may not be exactly as shown)

1. This Truck Guard is NOT COMPATIBLE with OEM Fog Lights.
Unplug the OEM Fog Light's Wiring Harness (if applicable).
2. Remove the OEM Front Bumper by removing the circled bolts shown in Figure 1a.
Retain OEM hardware for later use.

II. Installing the HERD Submounts and Truck Guard on truck.

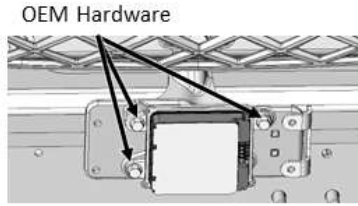

Figure 2a:
OEM Radar Sensor Bracket

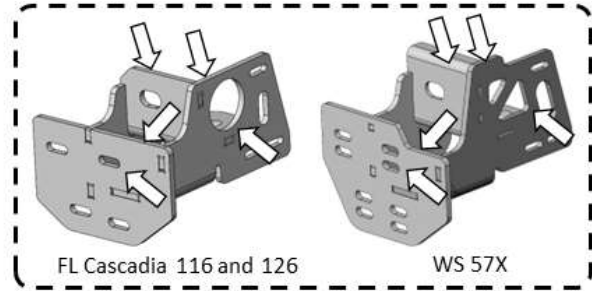

Figure 2e:
HERD Side Submounts Comparison (DS Shown)

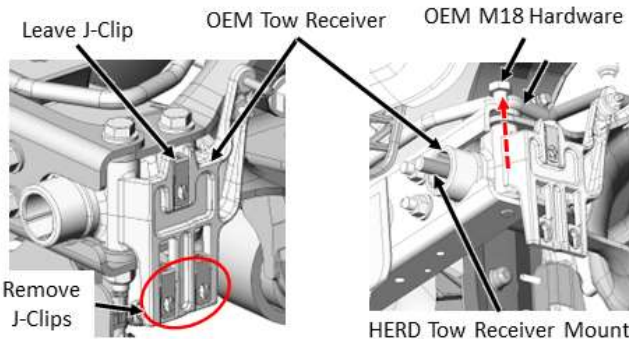

Figure 2b:
J-Clips (DS Shown)

Figure 2c: HERD Tow Receiver Mount (DS Shown)

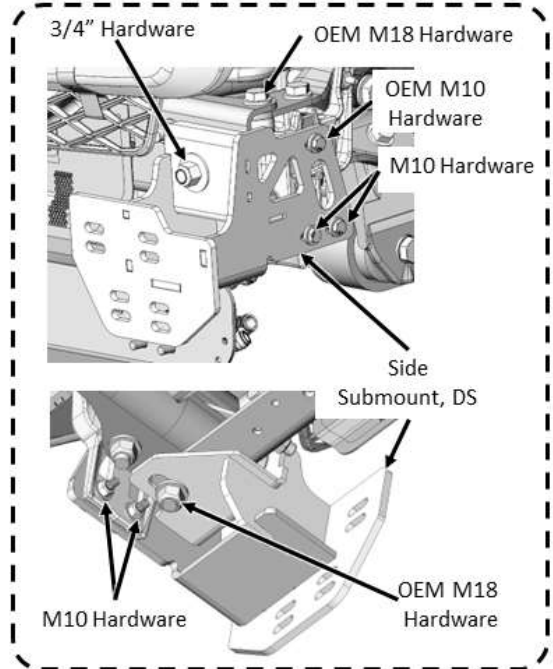

Figure 2f:
HERD Side Submount (DS Shown)

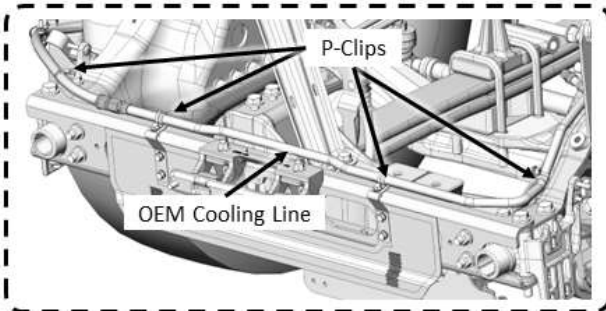

Figure 2d: OEM Cooling Line

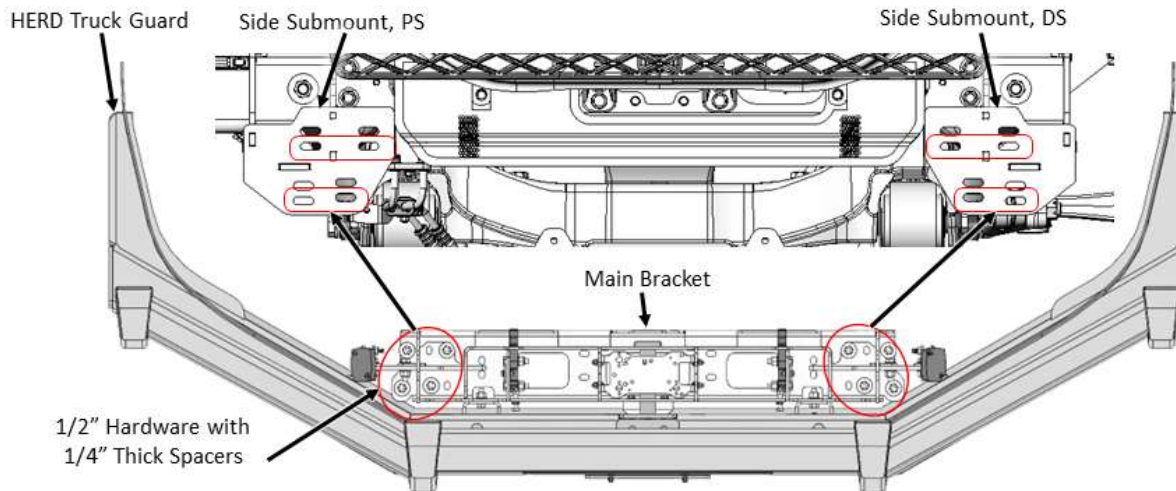

Figure 2g: HERD Truck Guard Assembly

Figure 2: HERD Submounts and Truck Guard Installation on a Truck

1. If the truck is equipped with Collision Avoidance System (CAS), disconnect the Radar Sensor and remove as shown in Figure 2a. Retain the Radar Sensor and hardware for later use.
2. Remove the bottom J-clips and leave the top J-clip on the truck's OEM Tow Receiver; see Figure 2b.
3. Insert HERD Tow Receiver Mount into the OEM Tow Receiver of the truck frame and rotate 90° to lock in place as shown in Figure 2c.
4. Remove the OEM M18 hardware and retain for later use as shown in Figure 2c. You may need to temporarily remove or loosen the P-Clips holding the OEM Cooling Line; see Figure 2d.
5. Install the HERD Side Submount using the OEM Hardware (M18 & M10), and HERD Hardware (3/4" & M10); as shown in Figure 2f. Fully tighten the OEM Hardware (M18 & M10). **Torque the M10 Hardware to 48 ft-lb, and the 3/4" Hardware to 240 ft-lb.** Do this one side at a time. Please use the specific Herd Side Submount for your Truck Model; see Figure 2e.
6. Repeat steps 2 to 5 on the other side of the truck.
7. Lift the Main Bracket and Truck Guard (opened) assembly and mount it to the truck. Fasten the Main Bracket to the HERD Side and Center Submounts using the provided 1/2" Hardware with 1/4" Thick washers as shown in Figure 2g. **Torque the 1/2" Hardware to 96 ft-lb.**
8. Re-install and tighten the P-clips holding the OEM Cooling Line that were previously removed or loosened.
9. Install Radar Sensor (if applicable) to the Herd Sensor Bracket using Radar Sensor Bracket Installation Procedure (S009).
10. Close the bumper and check the Slam Latch adjustment. If necessary, adjust the Slam Latch. Refer to Slam Latch Installation adjustment instructions (S012) to properly adjust your Slam Latch.

Important: Check mounting points' hardware after the first 5000 km and every 3-6 months. Re-torque if necessary.